

VI **co** Costacurta



Products for oil & gas, petrochemical, chemical

Costacurta



Milan head office



Founded in 1921, Costacurta started manufacturing woven cloths and crimped wire meshes in a factory based in Lecco and selling them from an office with adjacent shop in Milan.

Over the years Costacurta has grown constantly and has gradually become more present on international markets where it is highly appreciated for its quality products, characterised by their highly specialised and technological nature, and for the great attention paid to understanding and meeting specific customers' needs.

Today, Costacurta has approx. 220 employees, its sales offices in Milan, two factories, both in the province of Lecco, and a subsidiary in The Netherlands, Costacurta b.v.

Costacurta exports over 70% of its turnover and is a qualified supplier to the leading international companies that are involved in developing technology, providing engineering services and manufacturing systems and equipment for oil, petrochemical and chemical industries as well as the food, mechanical, textile, paper and wood industries.

Costacurta sales structure is organized into the following business lines:

- architectural wire mesh
- filtering elements
- conveyor belts
- products for oil & gas, petrochemical, chemical

Customer satisfaction and protection of the environment and workers' health are priority objectives to Costacurta. Consistently with this choice, Costacurta has implemented a quality management system conforming to standard ISO 9001, an environmental system conforming to standard ISO 14001 and an occupational health and safety system conforming to standard OHSAS 18001.

Costacurta's main manufacturing processes include metal wire weaving and other metal wire work processes, punching, drilling and milling of plates, laser cutting, rolling and welding. For the welding process in particular, specific operators' qualification, processes and checks have been envisaged according to standards ASME (American Society of Mechanical Engineers).

Costacurta's design and engineering expertise includes mechanical design and fabrication drawings of the supplied components, selection and process design of gas/liquid and liquid/liquid separators, gas/liquid inlet distributors and flow equalisers.

Costacurta also offers supervision services during finished product installation and after-sales service to customers for the development of new products.

For further information consult our website at the following address: www.costacurta.it

Garlate factory



Olginate factory





Reactor internals

In the typical configuration of a Radial Flow reactor, the reacting gas is conveyed radially on the catalytic bed through perforated plate distributors (scallops) located along the reactor walls or through the slots of an outer basket.

After having passed through the catalyst bed, the gas is collected in a centerpipe and conveyed to the next reaction stage.

There are also applications whereby the gas follows the same route in the opposite direction, in other words from the inside outwards, however the basic configuration of the internals is the same.

As well as scallops and centerpipes, other internals normally present in Radial Flow reactors are: inlet distributors, deflecting baffles, centerpipe supports, coverplates, shrouds and catalyst transfer pipes.

The main applications are: distribution of gas mixtures through catalytic beds and catalyst containment in the production of ammonia, in the extraction and treatment of gas and crude oil, in gas isomerization and aromatization units and in catalyst reforming units.

Costacurta is specialized in the construction of reactor internals; those most commonly used in the Radial Flow reactors are shown in the three-dimensional sketches below.

Moreover, starting from plates and wires made of stainless steel and special alloys, Costacurta manufactures wire meshes, perforated plates, and wedge wire screens, which are the filtering elements most widely used in the construction of centerpipes, scallops and outer baskets.

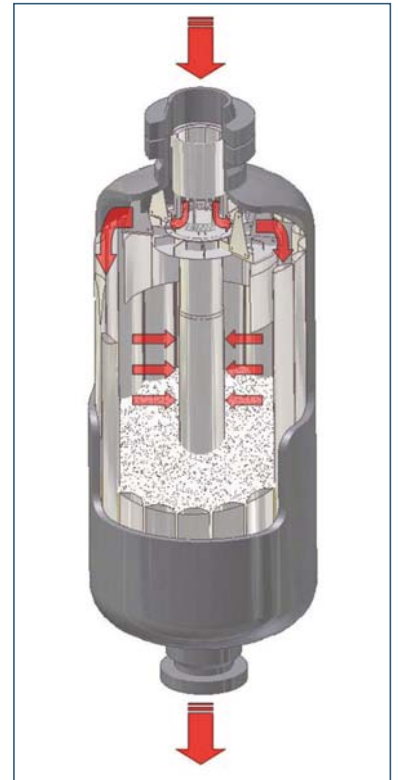

Radial Flow reactor internals

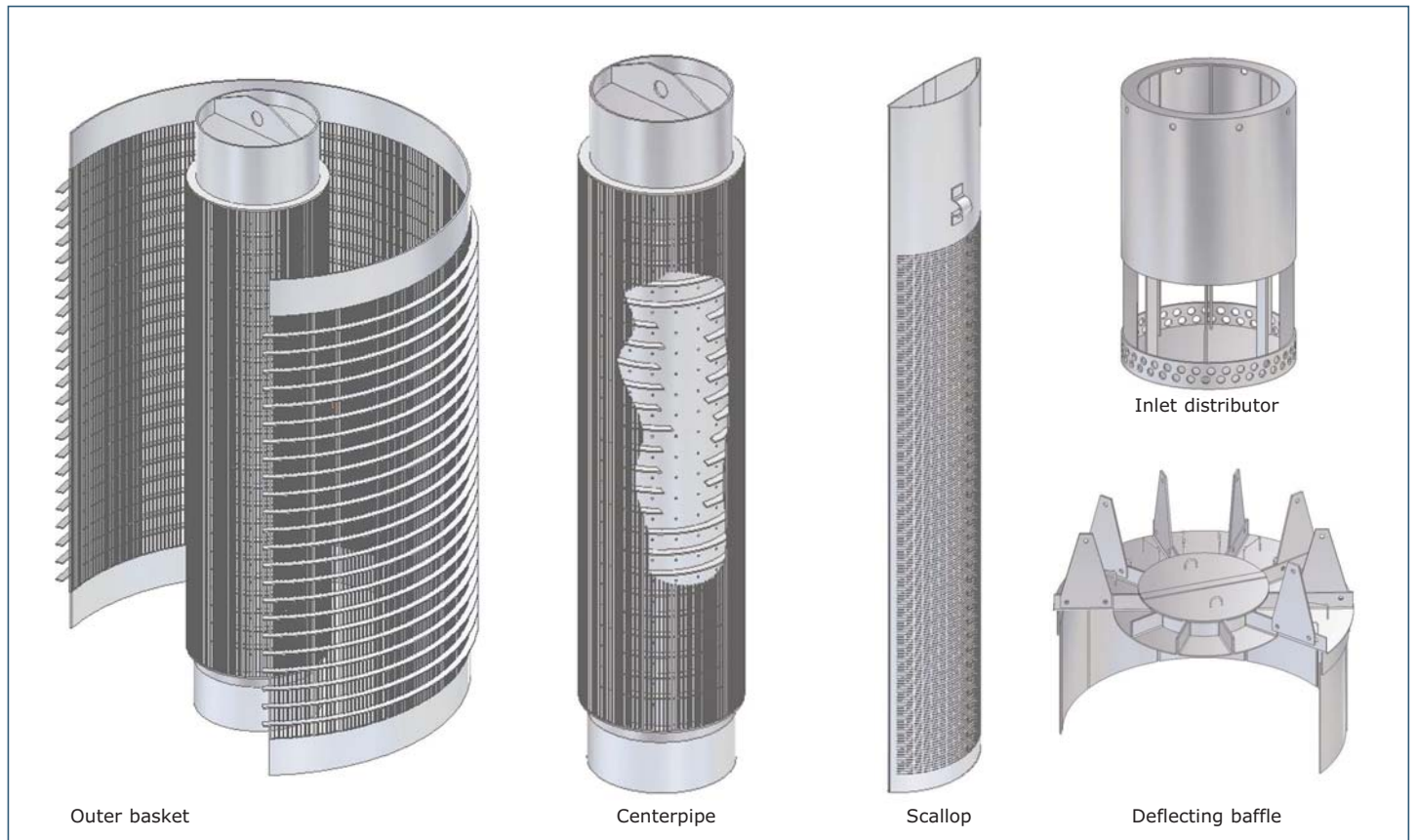



Reactor internals

In a typical two-bed configuration of a Down Flow reactor, the reacting liquid is distributed, using an inlet diffuser, on the liquid distributor tray underneath. This tray has the function of evenly distributing the liquid on the catalyst bed underneath, supported by the catalyst support assembly. Moving down the reactor, we come to the quench zone where the reacting liquid is cooled through gas injection and is then conveyed into a mixing chamber. From here, the liquid is distributed onto the next catalyst bed thanks to a liquid redistributor tray. The outlet collector positioned on the bottom of the reactor, supports the lower catalyst bed and enables the reacted liquid to be conveyed outside.

The main applications are: distribution and mixing of liquids and gases and catalyst support during hydrocracking, hydrotreating and isomerization processes as well as in the production of urea and methanol.

Costacurta is specialized in the construction of reactor internals; those most commonly used in the Down Flow reactors are shown in the three-dimensional sketches below.

Moreover, starting from plates and wires made of stainless steel and special alloys, Costacurta manufactures wire meshes and wedge wire screens which are the filtering elements most widely used in the construction of catalyst support grids and outlet collectors.

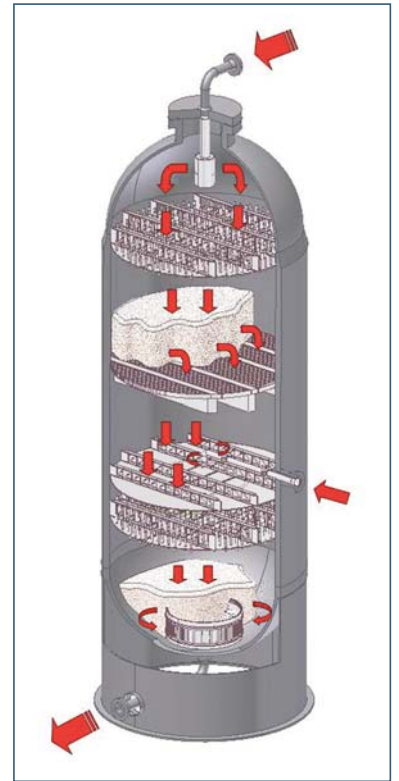

Down Flow reactor internals

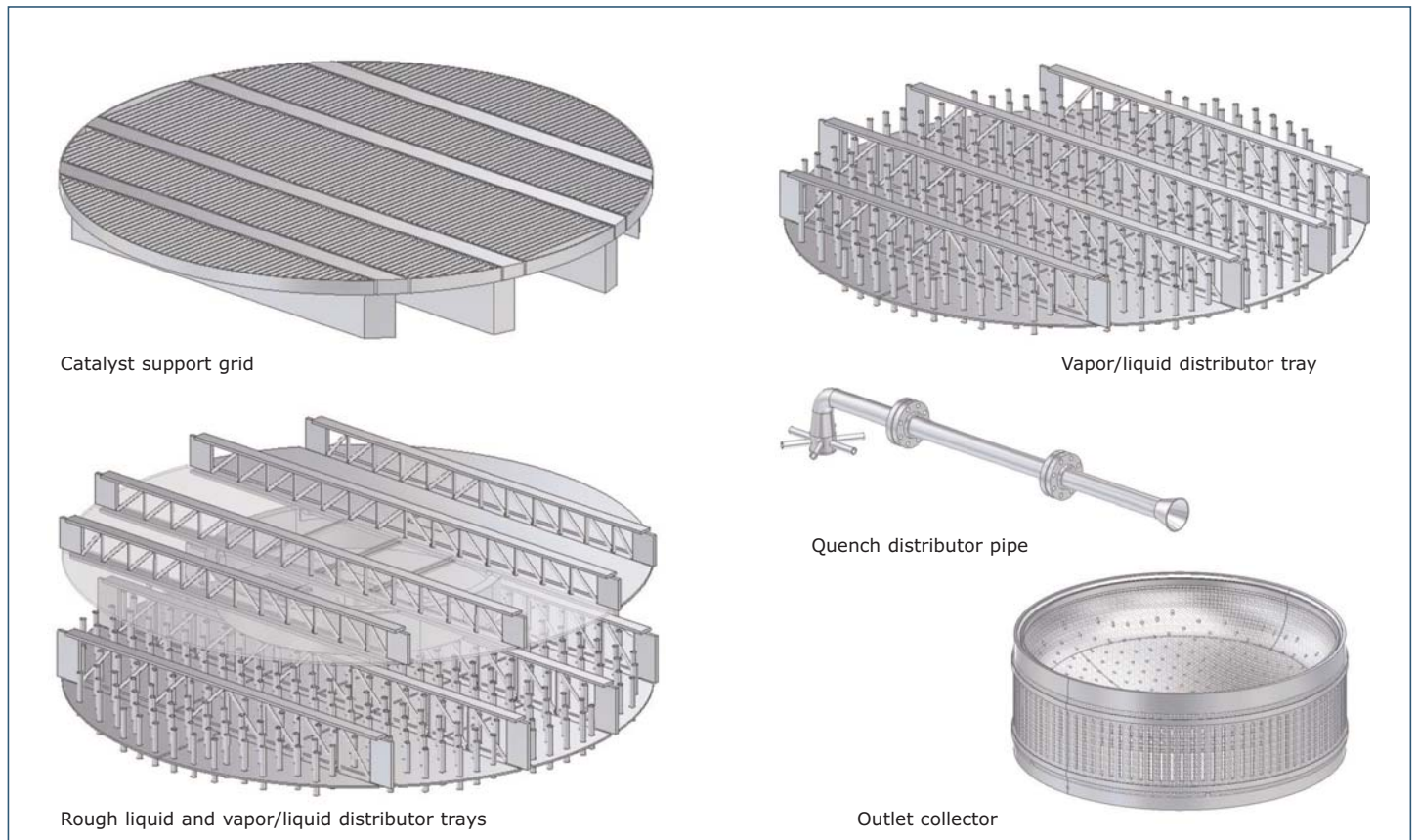



Hexagonal mesh and anchors

Hexagonal mesh and anchors are used for armouring refractory, anti-abrasive and anti-corrosive linings and are used in the oil, petrochemical, chemical, metallurgical, cement and various other industries. Costacurta produces numerous different kinds of hexagonal mesh and anchors to meet the technical specifications of the main process and engineering companies and has considerable experience in the elaboration of construction and assembly drawings, indispensable for facilitating installation. The level of automation achieved in the production process, thanks to the development of technologically advanced machines, enables high qualitative levels to be attained, together with the great flexibility necessary to meet very tight delivery times in emergency situations.

This family of products includes: VICO-Still®, VICO-Stillflex, VICO-Anchors, VICO-Rep S-bars and lining fittings.

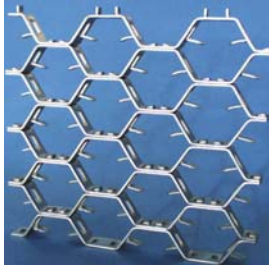

VICO-Still®



Laying of refractory lining

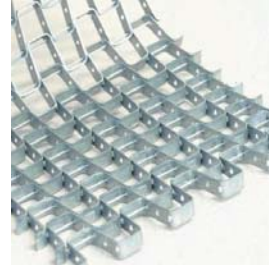

VICO-Stillflex



VICO-Anchors, VICO-Rep S-bars and lining fittings

Gas-liquid distributors and flow equalisers

Gas-liquid distributors are installed on the feed inlet nozzles of vessels (horizontal or vertical) or distillation columns to allow for uniform gas distribution in the inlet area and to promote a primary separation of the liquid present in the gas.

Flow equalisers are normally installed in horizontal vessels to uniformly distribute the vapour stream, break the waves and stop any foam present on the surface of the liquid, obtaining pre-separation of the larger droplets carried by the vapour stream upstream of the gas-liquid separators. Thanks to consolidated cooperation with university research institutes, Costacurta is able to develop fluid-dynamic studies for optimisation of design and sizing of the distributors and flow equalisers it produces. In this way it can meet the multiple needs for increasingly more sophisticated applications, above all regarding the sector of offshore platforms and gas-liquid and gas-liquid-liquid separators in general.

This family of products includes: vane feed inlet distributors and VICO-Straightners flow equalisers.



Vane feed inlet distributor



Vane feed inlet distributor



VICO-Straightner

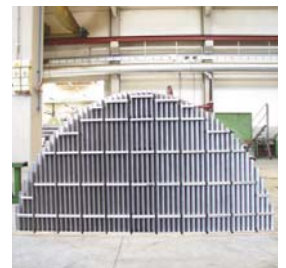

VICO-Straightner



Gas-liquid separators

Gas-liquid separators are generally used to remove droplets carried by vapour streams in order to reduce the loss of expensive products, increase product purity, prevent the corrosion of downstream equipment and reduce pollution of vapour waste into the atmosphere. These separators are widely used in the chemical, petrochemical and refining industries, in environmental protection applications and in many other industrial sectors. Costacurta can propose excellent solutions for a wide variety of gas-liquid separation related problems in all sectors of application. This is possible thanks to the wide range of separators produced, extensive experience in design and cooperation with university research institutes for performance control of separators using laboratory tests and fluid-dynamic studies. A willingness to cooperate with clients in resolving specific problems and the capacity to deal with emergency situations make Costacurta a trustworthy, reliable partner even for particularly critical projects. This family of products includes: VICO-Tex®, VICO-Vane, VICO-Chevron e VICO-Bsa.

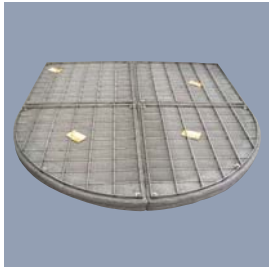

VICO-Tex®

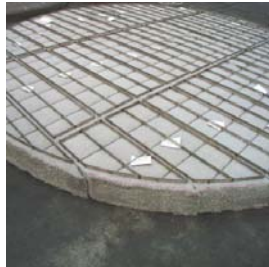

VICO-Tex®



VICO-Vane



VICO-Vane



VICO-Vane double V-bank

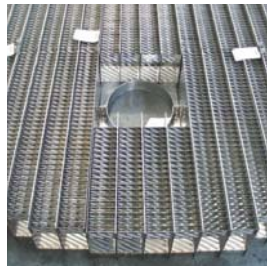

VICO-Chevron



VICO-Bsa

Liquid-liquid separators

Liquid-liquid separators are installed in horizontal and vertical vessels to increase the efficiency of separation between the two liquid phases, that cannot mix together, in order to reduce the loss of expensive products, increase the purity of each phase, stop the corrosion of downstream equipment and reduce pollution due to products that could be drained out into the surrounding environment. Over the years Costacurta has developed, together with qualified university research institutes, sophisticated calculation and checking programmes that can combine the design of gas-liquid and liquid-liquid separators. These developments have led to considerable results not only in the sector of offshore platforms but also for all phases of natural gas and oil treatment in the post-extraction phases. In addition to the development of production and technical skills, Costacurta has paid much attention to the evolution of the organizational structure to meet needs deriving from the management of complex projects, such as those that involve design and supply of all the internal components of gas-liquid separators and gas-liquid-liquid separators. This family of products includes: VICO-Tex® coalescers and VICO-Pack sloped plate coalescers.



VICO-Tex® coalescer



VICO-Pack sloped plate coalescer

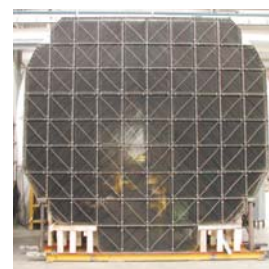

VICO-Pack sloped plate coalescer

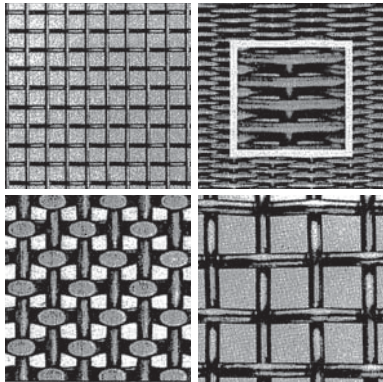

Wire cloths and meshes

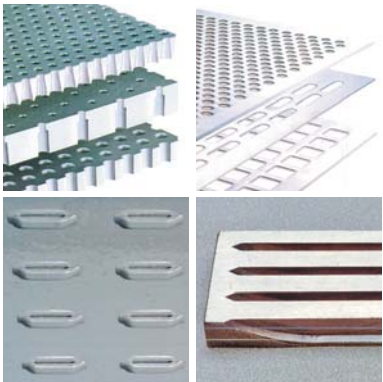

Perforated plates

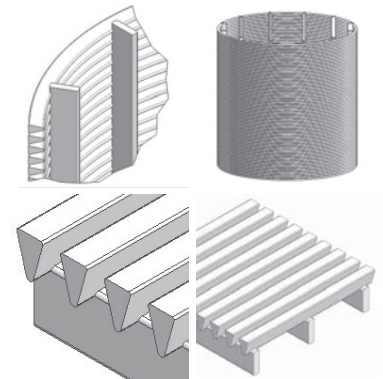

Wedge wire screen

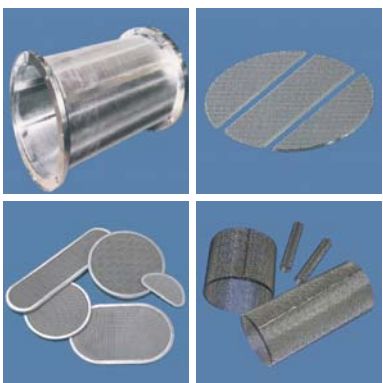

Fabricated parts

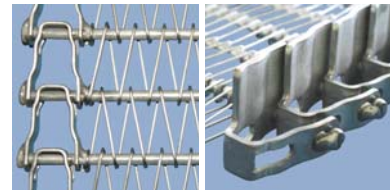

Conveyor belts for spiral towers

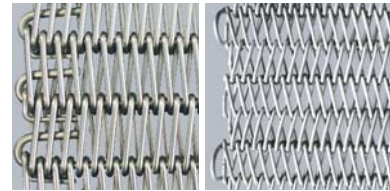

Straight conveyor belts for high temperatures

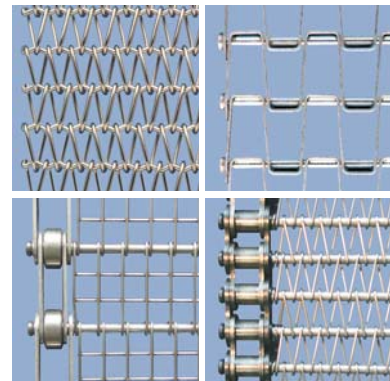

Straight conveyor belts



Special conveyors complete with structures

Filtering elements

Conveyor belts

Other Costacurta products



tcrc@costacurta.it

tcsc@costacurta.it

mktg@costacurta.it

Products for oil & gas, petrochemical, chemical

pressure vessels internals, armouring of refractory, anti-corrosive and anti-abrasive linings
separators

Marketing & business development

www.costacurta.it

Costacurta S.p.A.-VICO

Milan head office:

Via Grazioli, 30 - 20161 Milano MI - Tel: +39.02.66.20.20.66 - Fax: +39.02.66.20.20.99

Garlate factory:

Via Valmolina Inferiore, 130 - 23852 Garlate LC - Tel: +39.0341.68.15.46 - Fax: +39.0341.65.03.40

Olginate factory:

Loc. Capiate Via Adda, 20 - 23854 Olginate LC - Tel: +39.0341.68.15.46 - Fax: +39.0341.60.60.68